

JOB REFERENCE _____ /s/ _____

SUBMITTAL DATA:

Qty	Platform/Sensor	Cable Length	Display Increments
		FT	
		M	
		FT	
		M	
		FT	
		M	

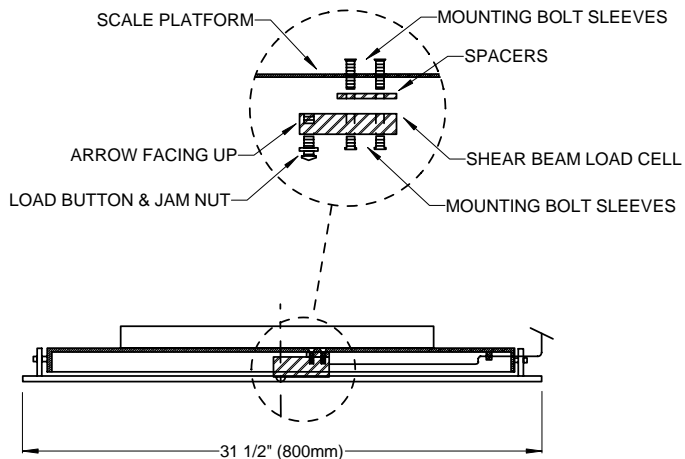
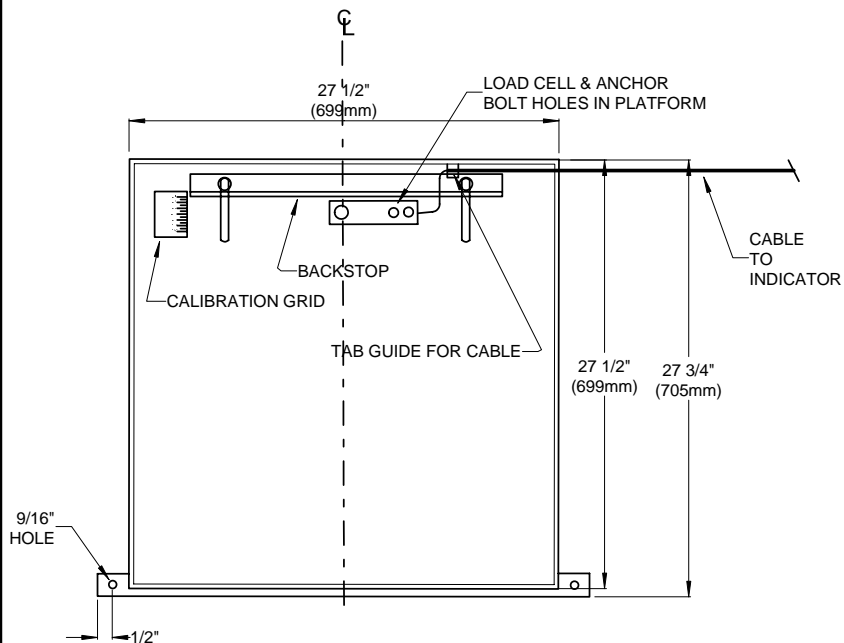

WIZARD INDICATOR MODEL NO: _____
 4-20mA OUTPUTS _____
 RELAYS _____ DRY CONTACT / SOLID STATE
 N.O. / N.C.
 OTHER OPTIONS: _____

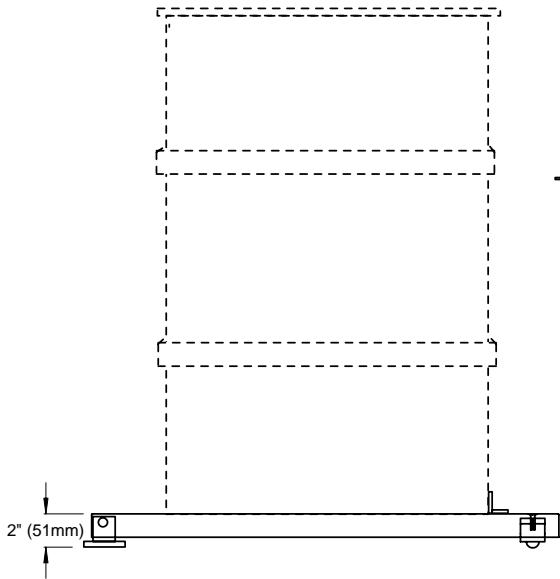
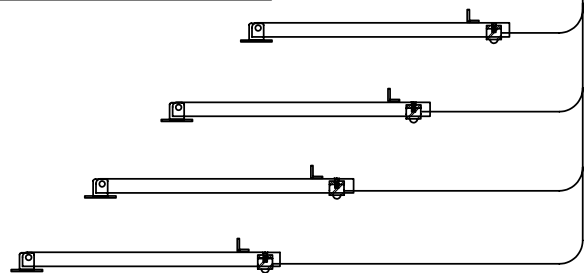

PLATFORM MODEL NO & CAPACITY:

- 27-DR4DS (400 lb)
- 27-DR5DS (500 lb)
- 27-DR6DS (600 lb)
- 27-DR8DS (800 lb)
- 27-DR10DS (1,000 lb)

Also available in metric.

Other Models:

_____ Capacity _____

_____ Capacity _____

316 SS MODEL (Platform with Load Cell)
 Add a second "S" to the end of the model number for Stainless Steel Platform

INDICATOR MODEL: (for WIZARD 4000 Indicator)

- 4000-1 1-Channel WIZARD 4000 Indicator
- 4000-2 2-Channel WIZARD 4000 Indicator
- 4000-3 3-Channel WIZARD 4000 Indicator
- 4000-4 4-Channel WIZARD 4000 Indicator

W.1.102