

\_\_\_\_\_ Model Number of Indicator (Lbs or Kgs \_\_\_\_\_)

\_\_\_\_\_ Model Number of Frame

\_\_\_\_\_ Feet of Cable (20' or 305 mm Std)

NOTE: Use 5/8" x 1-1/2" (16mm x 38mm) Anchor Bolts

RECOMMENDATION: 12" (305mm) minimum pad be used for each foot. DO NOT PREPOUR ANCHOR BOLTS. Use frame as template to avoid binding.

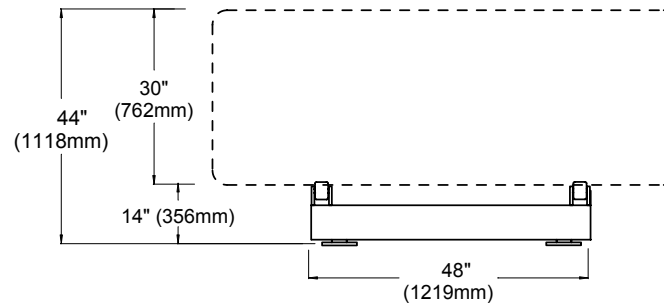

**MODEL NUMBERS (for Frame & Load Cell)**  
 DR240 (24,000 lbs)  
 DR120K (12,000 kgs)

**MODEL NUMBER (for SOLO 1000 Indicator)**  
 SR000-1 1-Channel  
 SR000-2 2-Channel

**S.1.134**

WEIGHT: 2160 Lbs (980 kgs)  
 (palletized for shipping)



1150-D Burnett Ave, Concord, CA 94520 USA  
 1-800-893-6723 US & Canada, Fax: 925-686-6713  
 www.forceflow.com / info@forceflow.com

**ELECTRONIC 6-TANK CHLOR-SCALE  
 FOR TON CONTAINERS  
 with SOLO INDICATOR (24,000 lb. Capacity)**

Drawn by: SLP  
 Date: 09/01/95  
 Revised: 10/23/03  
 Scale: NONE

Drawing Number

**30293**