

ECHO-SCALE™ ULTRASONIC LEVEL SENSOR

MONITOR CHEMICALS IN BULK STORAGE TANKS

- + Use "Stand-Alone" or with our WIZARD4000® or SOLO® G2 indicators
- + EZ-Cal™ Software for quick set-up and calibration
- + Integral level vials insure proper sensor alignment
- + Optional Echo-Tube™ Stillwell Mounting Kit guarantees a perfect installation

Echo-Scale™ Ultrasonic Level Sensors are ideal for monitoring sodium hypochlorite, fluoride, caustic and all other chemicals stored in bulk tanks at water and wastewater treatment plants.

The Echo-Scale sends out ultrasonic sound bursts to determine the chemical level in the tank. Then through our WIZARD4000® or SOLO® G2 indicators, the remaining chemical is displayed as a distance, weight or volume. When local indication is not required, the Echo-Scale operates "stand-alone" by sending its 4-20mA level signal straight to your computer.

The PVC/Polycarbonate/Kynar® design of the Echo-Scale makes it extremely durable. With its economical price and simple installation requirements, the Echo-Scale is the perfect system for new tanks and for retrofitting existing tanks.



NEW EZ-CAL™ SOFTWARE MAKES SET-UP AND CALIBRATION A SNAP! WIZARD 4000® MONITORS USAGE, FEED RATE AND REMAINING CHEMICAL IN UP TO 4 SEPARATE TANKS.



**NO FINGER POINTING.
NO FINE PRINT.™**



SPECIAL PULSE R™ PROGRAMMING MAKES THE ECHO-SCALE IDEAL FOR CHEMICALS THAT "GAS-OFF", SUCH AS SODIUM HYPOCHLORITE.



FORCE FLOW

ECHO-SCALE™ ULTRASONIC LEVEL SENSOR

MODELS AND ORDERING INFORMATION

Sensors include 20 ft (6.5m) of cable. Longer cable available upon request. Sensors are formatted for "Reverse Reading": 4mA when tank is empty, 20mA when tank is full.

SPECIFYING GUIDELINES: **1)** Include Level Sensor specification in chemical feed sections (not instrumentation section) to allow easy coordination with tank and other chemical feed apparatus. **2)** Specify a properly sized **NPT** coupler in the top of the tank, located preferably near the center or specify the Echo-tube™ Stillwell Kit. **3)** For chemicals that "Gas-Off", provide proper venting apparatus.

Monitor with the following indicators:
(Sold Separately)



WIZARD 4000®



SOLO® G2

MODEL	DR-5080	DR-5180	DR-5280
RANGE	4'-79" (76mm-2006mm)	1'-10' (0.3m-3m)	1'-20' (0.3m-6.5m)
OUTPUT	4-20mA		
HOUSING	Polycarbonate / PET Blend	PVC	
ACCURACY	+/- 0.25% of range with no temp gradient		
RATING	NEMA 4X	NEMA 6P, IP67	
RESOLUTION	0.1" (2.54mm)		
SUPPLY VOLTAGE	12-28 VDC (24 VDC Recommended)	24-30 VDC (24 VDC Recommended)	
TOTAL CURRENT DRAW	75mA max @ 24 VDC	50mA max @ 24 VDC	
BEAM PATTERN	9 Degrees off axis		
CABLE	3 Conductor with shield, 22 AWG, PVC jacket, 20' (6.5m)		
OPERATING TEMPERATURE	-40 to 60 Degrees C		

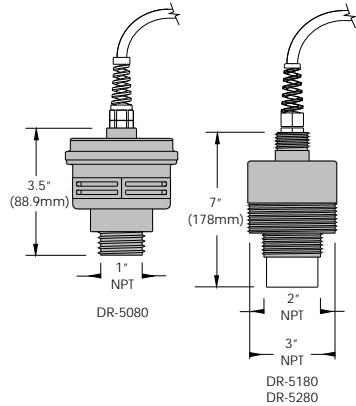

MODEL	RANGE	NPT
DR-5080	4" - 79"	1"
DR-5180	1' - 10'	2"
DR-5280	1' - 25'	3"

Specify the Echo-Tube™ Stillwell Kit for a perfect installation.

MODEL	LENGTH
ET5	5 FT (1525mm)
ET7	7 FT (2100mm)
ET9	9 FT (2750mm)

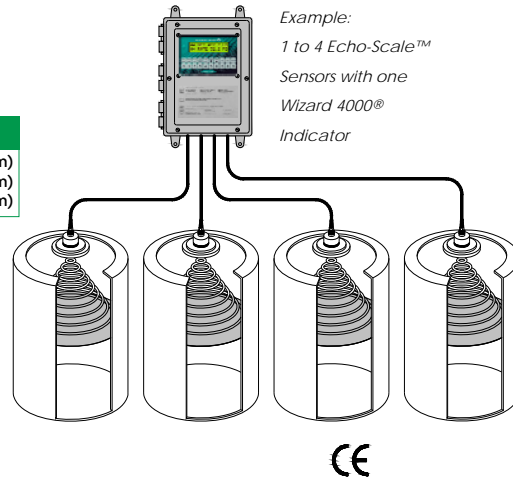

Example:
1 to 4 Echo-Scale™ Sensors with one WIZARD 4000® Indicator

SPECIFICATIONS

TYPICAL SPECIFICATION FOR ULTRASONIC LEVEL MONITORING SYSTEM

SENSOR

An Ultrasonic Level Sensor shall be provided for each tank. Sensor shall be of the self-contained type with a 4-20 mA output signal proportional to the tank level. Sensor shall have a range of ___ (up to 25) feet and shall have a NEMA 4X housing with ___ (20' standard) of sensor cable. Accuracy shall be better than 0.25% with no temperature gradient. Sensor shall be Echo-Scale™ Model No. ___ as manufactured by Force Flow, 2430 Stanwell Dr., Concord, CA 94520 USA or equal.

STILLWELL KIT

Kit shall include ___ (5,7,9 Ft.) pipe, articulating mounting flange to accommodate domed tanks, pressure relief port with hose barb and four(4) bolt and nut sets. All components shall be made of PVC plastic. Sealing O-ring and gasket shall be included. Stillwell kit shall be Echo-Tube™ Model No. ET ___ (5,7 or 9) as manufactured by Force Flow, 2430 Stanwell Dr., Concord, CA 94520 USA or equal.

BASIC DIGITAL INDICATOR

Sensor(s) shall display data on a local indicator of the digital LCD type. Indicator shall be housed in a NEMA 4X, UL listed enclosure. (Indicator configuration shall be menu driven) and indicator shall provide a 4-20 mA output signal for remote monitoring. Indicator shall have two adjustable set points for level alarms. Indicator shall be SOLO® G2 as manufactured by Force Flow, 2430 Stanwell Dr., Concord, CA 94520 USA or equal.

ADVANCED MULTI-CHANNEL DIGITAL INDICATOR

Sensor(s) shall display data on a local indicator of the digital LCD type. Indicator shall carry CE marking and shall be housed in a NEMA 4X, UL listed enclosure. Indicator shall independently monitor ___ (up to 4) separate sensors or scales, as well as monitor the totals of ___ (up to 4) tanks. Each channel shall display net remaining, daily usage, total amount used, rate of feed and days until empty. A data log function shall store the daily usage for each of the previous 10 days. Operator shall be able to monitor chemical by weight, volume, level or percent full. Indicator shall be WIZARD 4000® as manufactured by Force Flow, 2430 Stanwell Dr., Concord, CA 94520 USA or equal.

